

## PROCESSOR SUPERVISORY CIRCUITS WITH WINDOW-WATCHDOG

Check for Samples: [TPS3813J25-Q1](#), [TPS3813L30-Q1](#), [TPS3813K33-Q1](#), [TPS3813I50-Q1](#)

### FEATURES

- Qualified for Automotive Applications
- Window-Watchdog With Programmable Delay and Window Ratio
- 6-Pin SOT-23 Package
- Supply Current of 9  $\mu\text{A}$  (Typ)
- Power On Reset Generator With a Fixed Delay Time of 25 ms
- Precision Supply Voltage Monitor: 2.5 V, 3 V, 3.3 V, 5 V
- Open-Drain Reset Output
- Temperature Range  $-40^{\circ}\text{C}$  to  $125^{\circ}\text{C}$

### APPLICATIONS

- Applications Using DSPs, Microcontrollers, or Microprocessors
- Safety-Critical Systems
- Automotive Systems
- Heating Systems

### DESCRIPTION

The TPS3813 supervisory circuits provide circuit initialization and timing supervision, primarily for DSPs and processor-based systems.

During power on,  $\overline{\text{RESET}}$  is asserted when supply voltage ( $V_{\text{DD}}$ ) becomes higher than 1.1 V. Thereafter, the supervisory circuit monitors  $V_{\text{DD}}$  and keeps  $\overline{\text{RESET}}$  active as long as  $V_{\text{DD}}$  remains below the threshold voltage ( $V_{\text{IT}}$ ). An internal timer delays the return of the output to the inactive state (high) to ensure proper system reset. The delay time,  $t_d = 25$  ms typical, starts after  $V_{\text{DD}}$  has risen above the threshold voltage ( $V_{\text{IT}}$ ). When the supply voltage drops below the threshold voltage ( $V_{\text{IT}}$ ), the output becomes active (low) again. No external components are required. All the devices of this family have a fixed-sense threshold voltage ( $V_{\text{IT}}$ ) set by an internal voltage divider.

For safety-critical applications, the TPS3813 family incorporates a window-watchdog with programmable delay and window ratio. The upper limit of the watchdog time-out can be set by either connecting WDT to GND or  $V_{\text{DD}}$ , or by using an external capacitor. The lower limit, and thus the window ratio, is set by connecting WDR to GND or  $V_{\text{DD}}$ . The supervised processor now needs to trigger the TPS3813 within this window not to assert a  $\overline{\text{RESET}}$ .

The product spectrum is designed for supply voltages of 2.5 V, 3 V, 3.3 V, and 5 V. The circuits are available in a 6-pin SOT-23 package.

The TPS3813 devices are characterized for operation over a temperature range of  $-40^{\circ}\text{C}$  to  $125^{\circ}\text{C}$ .

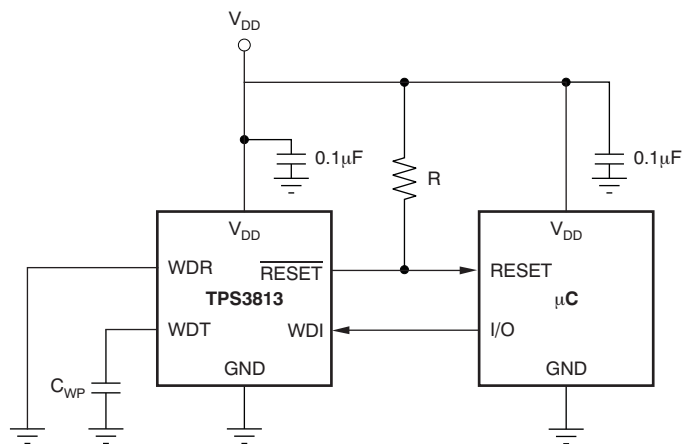

Typical Operating Circuit

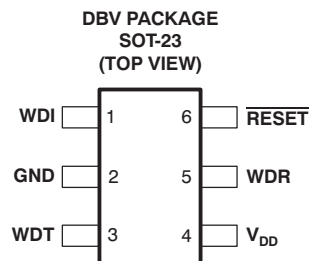

Please be aware that an important notice concerning availability, standard warranty, and use in critical applications of Texas Instruments semiconductor products and disclaimers thereto appears at the end of this data sheet.

All trademarks are the property of their respective owners.



This integrated circuit can be damaged by ESD. Texas Instruments recommends that all integrated circuits be handled with appropriate precautions. Failure to observe proper handling and installation procedures can cause damage.

ESD damage can range from subtle performance degradation to complete device failure. Precision integrated circuits may be more susceptible to damage because very small parametric changes could cause the device not to meet its published specifications.

**ORDERING INFORMATION<sup>(1)</sup>**

T <sub>A</sub>	THRESHOLD VOLTAGE	PACKAGE <sup>(2)</sup>		ORDERABLE PART NUMBER	TOP-SIDE MARKING
-40°C to 125°C	2.25 V	SOT-23 – DBV	Reel of 3000	TPS3813J25QDBVRQ1	PREVIEW
	2.64 V			TPS3813L30QDBVRQ1	PREVIEW
	2.93 V			TPS3813K33QDBVRQ1	PFBQ
	4.55 V			TPS3813I50QDBVRQ1	PFBI

- (1) For the most current package and ordering information, see the Package Option Addendum at the end of this document, or see the TI web site at [www.ti.com](http://www.ti.com).
- (2) Package drawings, thermal data, and symbolization are available at [www.ti.com/packaging](http://www.ti.com/packaging).

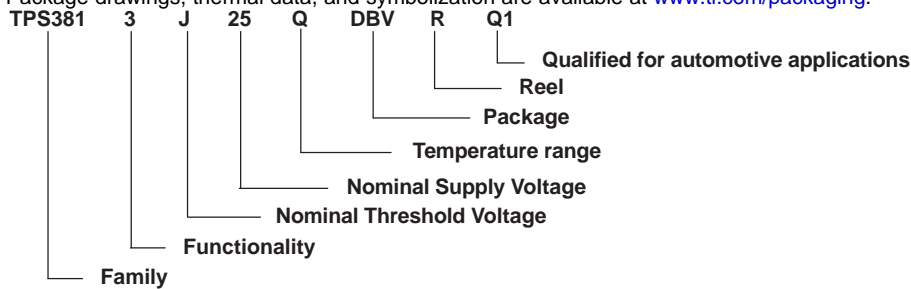

**DBV PACKAGE  
SOT-23-6  
(TOP VIEW)**

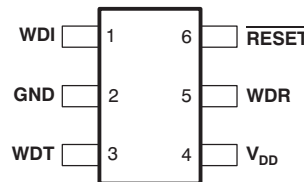

**PIN FUNCTIONS**

PIN		I/O	DESCRIPTION
NAME	NO.		
GND	2	I	Ground
$\overline{\text{RESET}}$	6	O	Open-drain reset output
V <sub>DD</sub>	4	I	Supply voltage and supervising input
WDI	1	I	Watchdog timer input
WDR	5	I	Selectable watchdog window ratio input
WDT	3	I	Programmable watchdog delay input

**FUNCTION/TRUTH TABLE**

V <sub>DD</sub> > V <sub>IT</sub>	$\overline{\text{RESET}}$
0	L
1	H

Figure 1. FUNCTIONAL SCHEMATIC

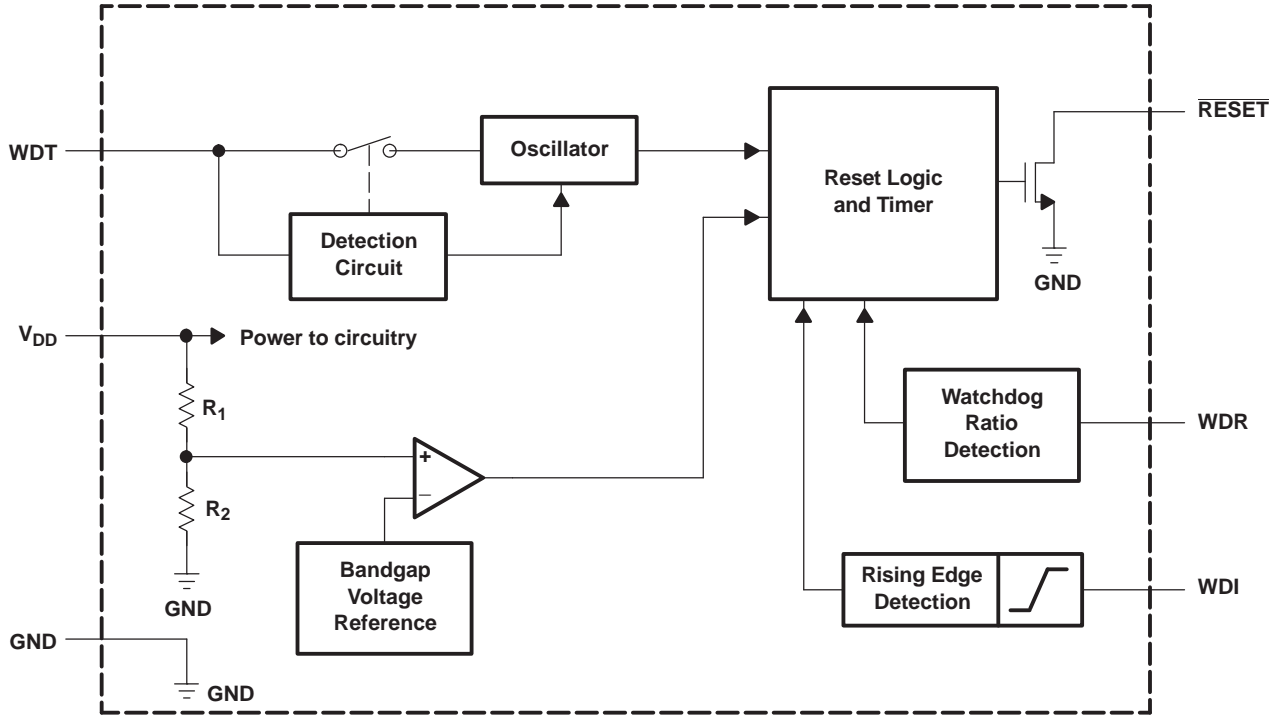
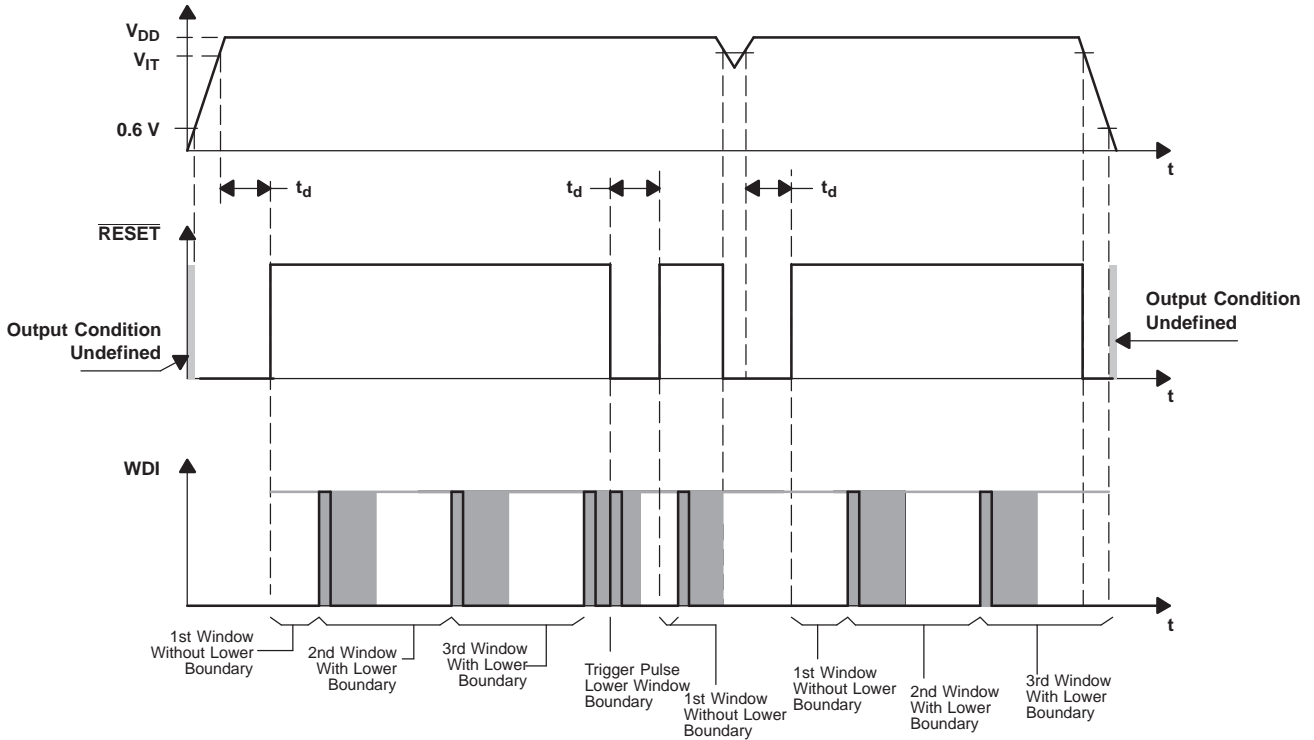

Figure 2. TIMING DIAGRAM



The lower boundary of the watchdog window starts with the rising edge of the WDI trigger pulse. At the same time, all internal timers are reset. If an external capacitor is used, the lower boundary is impacted due to the different oscillator frequency. This is described in more detail in the following section. The timing diagram and especially the shaded boundary is prepared in a nonreal ratio scale to better visualize the description.

## DETAILED DESCRIPTION

### Implemented Window-Watchdog Settings

There are two different ways to set up the watchdog window. The first way is to use the implemented timing, which is a default setting. Or, the default settings can be activated by wiring the WDT and WDR pin to  $V_{DD}$  or GND. There are four different timings available with these settings, as shown in the following table.

SELECTED OPERATION MODE		WINDOW FRAME	LOWER WINDOW FRAME
WDT = 0 V	WDR = 0 V	Max = 0.3 s	Max = 9.46 ms
		Typ = 0.25 s	Typ = 7.86 ms
		Min = 0.2 s	Min = 6.27 ms
	WDR = $V_{DD}$	Max = 0.3 s	Max = 2.43 ms
		Typ = 0.25 s	Typ = 2 ms
		Min = 0.2 s	Min = 1.58 ms
WDT = $V_{DD}$	WDR = 0 V	Max = 3 s	Max = 93.8 ms
		Typ = 2.5 s	Typ = 78.2 ms
		Min = 2 s	Min = 62.5 ms
	WDR = $V_{DD}$	Max = 3 s	Max = 23.5 ms
		Typ = 2.5 s	Typ = 19.6 ms
		Min = 2 s	Min = 15.6 ms

To visualize the values named in the table, a timing diagram is shown in [Figure 3](#). It is used to describe the upper and lower boundary settings. For an application, the important boundaries are the  $t_{\text{boundary,max}}$  and  $t_{\text{window,min}}$ . Within these values, the watchdog timer should be retriggered to avoid a timeout condition or a boundary violation in the event of a trigger pulse in the lower boundary. The values in the table above are typical and worst case conditions. They are valid over the whole temperature range of  $-40^{\circ}\text{C}$  to  $125^{\circ}\text{C}$ .

In the shaded area of [Figure 3](#), it cannot be predicted if the device will detect a violation or not and release a reset. This is also the case between the boundary tolerance of  $t_{\text{boundary,min}}$  and  $t_{\text{boundary,max}}$  as well as between  $t_{\text{window,min}}$  and  $t_{\text{window,max}}$ . It is important to set up the trigger pulses accordingly to avoid violations in these areas.

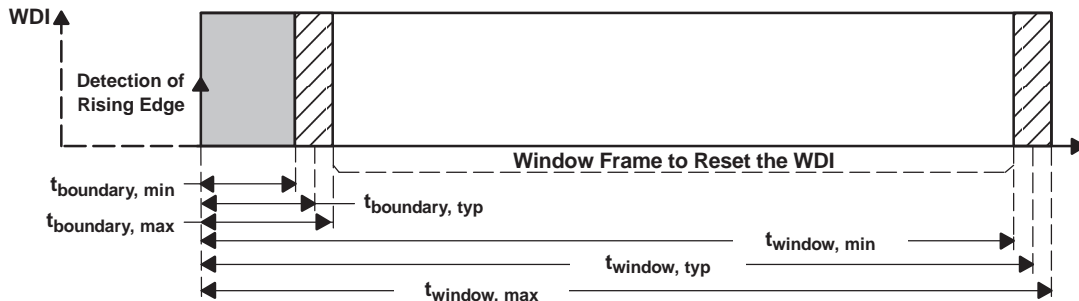

Figure 3. Upper and Lower Boundary Visualization

### Timing Rules of Window-Watchdog

After the reset of the supervisor is released, the lower boundary of the first WDI window is disabled. However, after the first WDI pulse low-to-high transition is detected, the lower boundary function of the window is enabled. All further WDI pulses need to fit into the configured window frame.

## Programming Window-Watchdog Using an External Capacitor

The upper boundary of the watchdog timer can be set by an external capacitor connected between the WDT pin and GND. Common consumer electronic capacitors can be used to implement this feature. They should have low ESR and low tolerances since the tolerances have to be considered if the calculations are performed. The first formula is used to calculate the upper window frame. After calculating the upper window frame, the lower boundary can be calculated. As in the last example, the most important values are the  $t_{\text{boundary,max}}$  and  $t_{\text{window,min}}$ . The trigger pulse has to fit into this window frame.

The external capacitor should have a value between a minimum of 155 pF and a maximum of 63 nF.

SELECTED OPERATION MODE		WINDOW FRAME
WDT = external capacitor $C_{\text{(ext)}}$	WDR = 0 V and WDR = $V_{\text{DD}}$	$t_{\text{window,max}} = 1.25 \times t_{\text{window,typ}}$
		$t_{\text{window,min}} = 0.75 \times t_{\text{window,typ}}$

$$t_{\text{window,typ}} = \left( \frac{C_{\text{(ext)}}}{15.55 \text{ pF}} + 1 \right) \times 6.25 \text{ ms} \quad (1)$$

### Lower-Boundary Calculation

The lower boundary can be calculated based on the values given in the switching characteristics. Additionally, facts have to be taken into account to verify that the lower boundary is where it is expected. Since the internal oscillator of the window watchdog is running free, any rising edge at the WDI pin is taken into account at the next internal clock cycle. This happens regardless of the external source. Since the shift between internal and external clock is not known, it is best to consider the worst-case condition for calculating this value.

SELECTED OPERATION MODE		LOWER BOUNDARY OF FRAME
WDT = external capacitor $C_{\text{(ext)}}$	WDR = 0 V	$t_{\text{boundary,max}} = t_{\text{window,max}} / 23.5$
		$t_{\text{boundary,typ}} = t_{\text{window,typ}} / 25.8$
		$t_{\text{boundary,min}} = t_{\text{window,min}} / 28.7$
	WDR = $V_{\text{DD}}$	$t_{\text{boundary,max}} = t_{\text{window,max}} / 51.6$
		$t_{\text{boundary,typ}} = t_{\text{window,typ}} / 64.5$
		$t_{\text{boundary,min}} = t_{\text{window,min}} / 92.7$

### Watchdog Software Considerations

To benefit from the window watchdog feature and help the watchdog timer monitor the software execution more closely, it is recommended that the watchdog be set and reset at different points in the program rather than pulsing the watchdog input periodically by using the prescaler of a microcontroller or DSP. Furthermore, the watchdog trigger pulses should be set to different timings inside the window frame to release a defined reset, if the program should hang in any subroutine. This allows the window watchdog to detect timeouts of the trigger pulse as well as pulses that distort the lower boundary.

## Application Example

A typical application example (see [Figure 4](#)) is used to describe the function of the watchdog in more detail.

To configure the window watchdog function, two pins are provided by the TPS3813. These pins set the window timeout and ratio.

The window watchdog ratio is a fixed ratio, which determines the lower boundary of the window frame. It can be configured in two different frame sizes.

If the window watchdog ratio pin (WDR) is set to  $V_{DD}$ , Position 1 in [Figure 4](#), then the lower window frame is a value based on a ratio calculation of the overall window timeout size: For the watchdog timeout pin (WDT) connected to GND, it is a ratio of 1:124.9, for WDT connected to  $V_{DD}$ , it is a ratio of 1:127.7, and for an external capacitor connected to WDT, it is a ratio of 1:64.5.

If the window watchdog ratio pin (WDR) is set to GND, Position 2, the lower window frame will be a value based on a ratio calculation of the overall window timeout size: For the watchdog timeout pin (WDT) connected to GND, it will be a ratio of 1:31.8, for WDT connected to  $V_{DD}$  it will be 1:32, and for an external capacitor connected to WDT it will be 1:25.8.

The watchdog timeout can be set in two fixed timings of 0.25 second and 2.5 seconds for the window or can be programmed by connecting an external capacitor with a low leakage current at WDT.

Example: If the watchdog timeout pin (WDT) is connected to  $V_{DD}$ , the timeout is 2.5 seconds. If the window watchdog ratio pin (WDR) is set in this configuration to a ratio of 1:127.7 by connecting the pin to  $V_{DD}$ , the lower boundary is 19.6 ms.

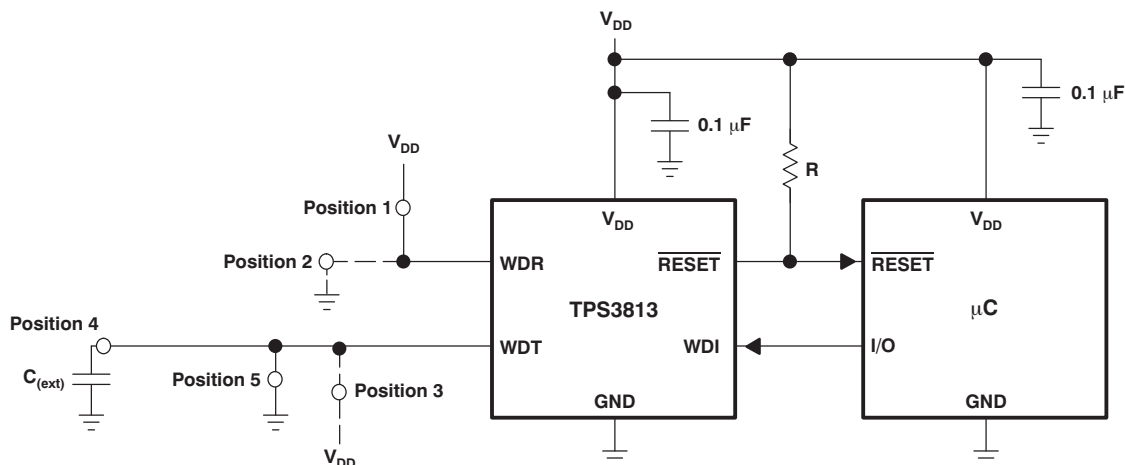

Figure 4. Application Example

## ABSOLUTE MAXIMUM RATINGS<sup>(1)</sup>

over operating free-air temperature range (unless otherwise noted)

V <sub>DD</sub>	Supply voltage <sup>(2)</sup>	7 V
	RESET	–0.3 V to (V <sub>DD</sub> + 0.3 V)
	All other pins <sup>(2)</sup>	–0.3 V to 7 V
I <sub>OL</sub>	Maximum low output current	5 mA
I <sub>OH</sub>	Maximum high output current	–5 mA
I <sub>IK</sub>	Input clamp current (V <sub>I</sub> < 0 or V <sub>I</sub> > V <sub>DD</sub> )	±20 mA
I <sub>OK</sub>	Output clamp current (V <sub>O</sub> < 0 or V <sub>O</sub> > V <sub>DD</sub> )	±20 mA
	Continuous total power dissipation	See <a href="#">Dissipation Ratings</a>
T <sub>A</sub>	Operating free-air temperature range	–40°C to 125°C
T <sub>stg</sub>	Storage temperature range	–65°C to 150°C
	Soldering temperature	260°C

- (1) Stresses beyond those listed under *absolute maximum ratings* may cause permanent damage to the device. These are stress ratings only, and functional operation of the device at these or any other conditions beyond those indicated under *recommended operating conditions* is not implied. Exposure to absolute-maximum-rated conditions for extended periods may affect device reliability.
- (2) All voltage values are with respect to GND. For reliable operation the device should not be operated at 7 V for more than t = 1000h continuously.

## DISSIPATION RATINGS

PACKAGE	T <sub>A</sub> < 25°C POWER RATING	DERATING FACTOR ABOVE T <sub>A</sub> = 25°C	T <sub>A</sub> = 70°C POWER RATING	T <sub>A</sub> = 85°C POWER RATING
DBV	437 mW	3.5 mW/°C	280 mW	227 mW

## RECOMMENDED OPERATING CONDITIONS

at specified temperature range

		MIN	MAX	UNIT
V <sub>DD</sub>	Supply voltage	2	6	V
V <sub>I</sub>	Input voltage	0	V <sub>DD</sub> + 0.3	V
V <sub>IH</sub>	High-level input voltage	0.7 × V <sub>DD</sub>		V
V <sub>IL</sub>	Low-level input voltage		0.3 × V <sub>DD</sub>	V
Δt/ΔV	Input transition rise and fall rate		100	ns/V
t <sub>w</sub>	Pulse width of WDI trigger pulse	50		ns
T <sub>A</sub>	Operating free-air temperature range	–40	125	°C

## ELECTRICAL CHARACTERISTICS

over recommended operating free-air temperature range (unless otherwise noted).

PARAMETER		TEST CONDITIONS	MIN	TYP	MAX	UNIT	
V <sub>OL</sub>	Low-level output voltage	V <sub>DD</sub> = 2 V to 6 V, I <sub>OL</sub> = 500 μA			0.2	V	
		V <sub>DD</sub> = 3.3 V, I <sub>OL</sub> = 2 mA			0.4		
		V <sub>DD</sub> = 6 V, I <sub>OL</sub> = 4 mA			0.4		
Power up reset voltage <sup>(1)</sup>		V <sub>DD</sub> ≥ 1.1 V, I <sub>OL</sub> = 50 μA			0.2	V	
V <sub>IT</sub>	Negative-going input threshold voltage <sup>(2)</sup>	TPS3813J25		2.2	2.25	2.3	V
		TPS3813L30		2.58	2.64	2.7	
		TPS3813K33		2.87	2.93	3	
		TPS3813I50		4.45	4.55	4.65	
V <sub>hys</sub>	Hysteresis	TPS3813J25		30		mV	
		TPS3813L30		35			
		TPS3813K33		40			
		TPS3813I50		60			
I <sub>IH</sub>	High-level input current	WDI, WDR	WDI = V <sub>DD</sub> = 6 V, WDR = V <sub>DD</sub> = 6 V	-125		125	nA
		WDT	WDT = V <sub>DD</sub> = 6 V, V <sub>DD</sub> > V <sub>IT</sub> , $\overline{\text{RESET}}$ = High	-125		125	
I <sub>IL</sub>	Low-level input current	WDI, WDR	WDI = 0 V, WDR = 0 V, V <sub>DD</sub> = 6 V	-125		125	nA
		WDT	WDT = 0 V, V <sub>DD</sub> > V <sub>IT</sub> , $\overline{\text{RESET}}$ = High	-125		125	
I <sub>OH</sub>	High-level output current	V <sub>DD</sub> = V <sub>IT</sub> + 0.2 V, V <sub>OH</sub> = V <sub>DD</sub>				25	nA
I <sub>DD</sub>	Supply current	V <sub>DD</sub> = 2 V output unconnected		9		13	μA
		V <sub>DD</sub> = 5 V output unconnected		20		25	
C <sub>i</sub>	Input capacitance	V <sub>I</sub> = 0 V to V <sub>DD</sub>		5			pF

(1) The lowest supply voltage at which  $\overline{\text{RESET}}$  becomes active. t<sub>r</sub>, V<sub>DD</sub> ≥ 15 μs/V.

(2) To ensure best stability of the threshold voltage, a bypass capacitor (ceramic, 0.1 μF) should be placed near to the supply terminals.

## TIMING REQUIREMENTS

R<sub>L</sub> = 1 MΩ, C<sub>L</sub> = 50 pF, T<sub>A</sub> = -40°C to 125°C

PARAMETER	TEST CONDITIONS	MIN	MAX	UNIT
t <sub>w</sub>	Pulse width at V <sub>DD</sub>	V <sub>DD</sub> = V <sub>IT-</sub> + 0.2 V, V <sub>DD</sub> = V <sub>IT-</sub> - 0.2 V	3	μs

## SWITCHING CHARACTERISTICS

R<sub>L</sub> = 1 MΩ, C<sub>L</sub> = 50 pF, T<sub>A</sub> = -40°C to 125°C

PARAMETER		TEST CONDITIONS	MIN	TYP	MAX	UNIT	
t <sub>d</sub>	Delay time	V <sub>DD</sub> ≥ V <sub>IT</sub> + 0.2 V (see timing diagram)	20	25	30	ms	
t <sub>t(out)</sub>	Watchdog time-out	Upper limit	WDT = 0 V	0.2	0.25	0.3	s
		WDT = V <sub>DD</sub>	2	2.5	3		
		WDT = programmable <sup>(1)</sup>		See <sup>(2)</sup>		ms	
Watchdog window ratio		WDR = 0 V, WDT = 0 V		1:31.8			
		WDR = 0 V, WDT = V <sub>DD</sub>		1:32			
		WDR = 0 V, WDT = programmable		1:25.8			
		WDR = V <sub>DD</sub> , WDT = 0 V		1:124.9			
		WDR = V <sub>DD</sub> , WDT = V <sub>DD</sub>		1:127.7			
		WDR = V <sub>DD</sub> , WDT = programmable		1:64.5			
t <sub>PHL</sub>	Propagation (delay) time, high-to-low-level output	V <sub>DD</sub> to $\overline{\text{RESET}}$ delay	V <sub>IL</sub> = V <sub>IT</sub> - 0.2 V, V <sub>IH</sub> = V <sub>IT</sub> + 0.2 V	30	50	μs	

(1) 155 pF < C<sub>(ext)</sub> < 63 nF

(2) (C<sub>(ext)</sub> ÷ 15.55 pF + 1) × 6.25 ms

TYPICAL CHARACTERISTICS

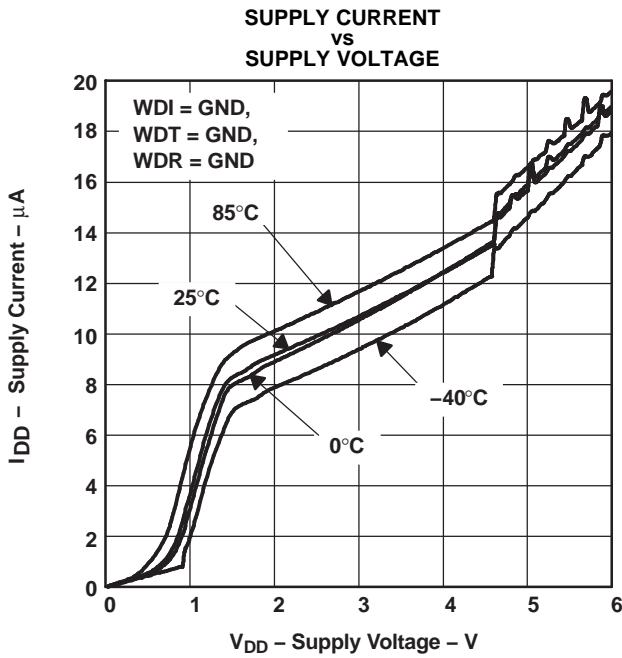

Figure 5.

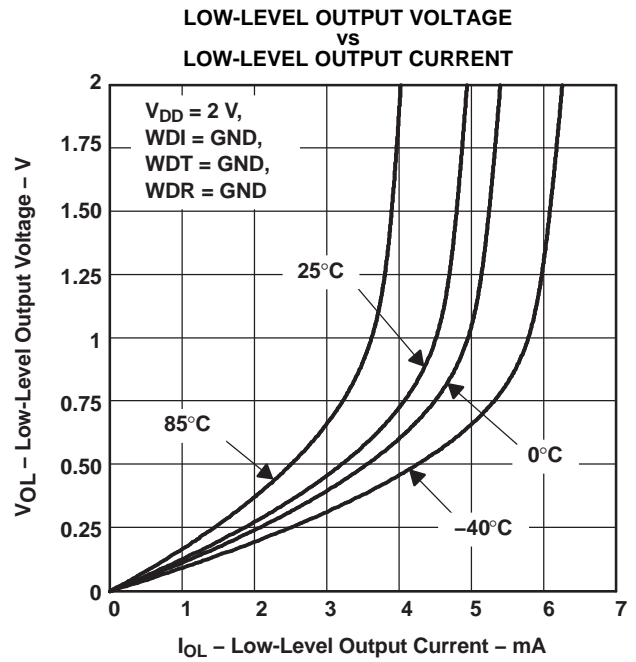

Figure 6.

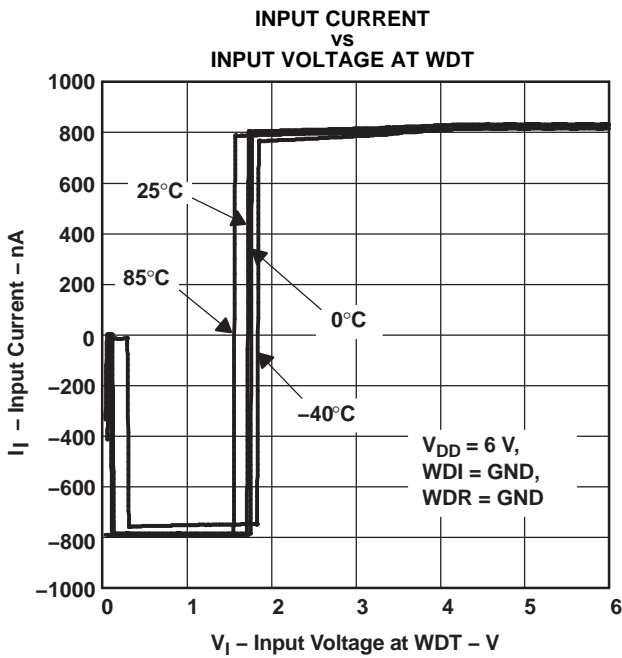

Figure 7.

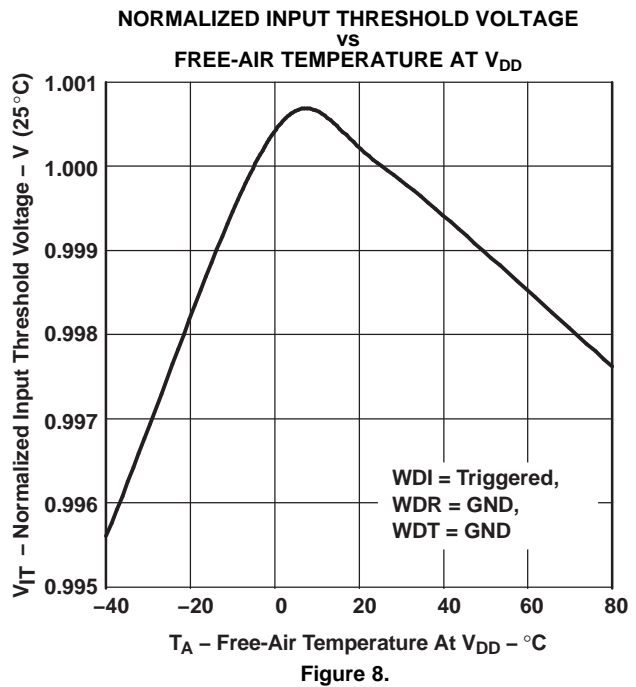

Figure 8.

### TYPICAL CHARACTERISTICS (continued)

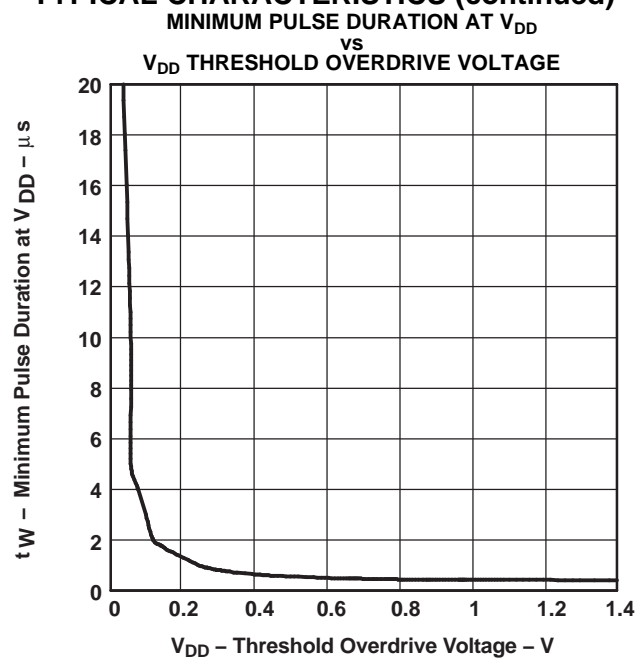

Figure 9.

## REVISION HISTORY

Changes from Revision A (November 2008) to Revision B	Page
<ul style="list-style-type: none"><li>Changed value from 47 pF to 155 pF. ....</li></ul>	5

Changes from Revision B (May 2012) to Revision C	Page
<ul style="list-style-type: none"><li>Deleted banner stating that TPS3813K33-Q1 is <i>Not Recommended for New Designs</i> .....</li></ul>	9

**PACKAGING INFORMATION**

Orderable Device	Status (1)	Package Type	Package Drawing	Pins	Package Qty	Eco Plan (2)	Lead/Ball Finish	MSL Peak Temp (3)	Op Temp (°C)	Device Marking (4/5)	Samples
TPS3813I50QDBVRQ1	ACTIVE	SOT-23	DBV	6	3000	Green (RoHS & no Sb/Br)	CU NIPDAU	Level-1-260C-UNLIM	-40 to 125	PFBI	<a href="#">Samples</a>
TPS3813K33QDBVRQ1	ACTIVE	SOT-23	DBV	6	3000	Green (RoHS & no Sb/Br)	CU NIPDAU	Level-1-260C-UNLIM	-40 to 125	PFBQ	<a href="#">Samples</a>

(1) The marketing status values are defined as follows:

**ACTIVE:** Product device recommended for new designs.

**LIFEBUY:** TI has announced that the device will be discontinued, and a lifetime-buy period is in effect.

**NRND:** Not recommended for new designs. Device is in production to support existing customers, but TI does not recommend using this part in a new design.

**PREVIEW:** Device has been announced but is not in production. Samples may or may not be available.

**OBSOLETE:** TI has discontinued the production of the device.

(2) Eco Plan - The planned eco-friendly classification: Pb-Free (RoHS), Pb-Free (RoHS Exempt), or Green (RoHS & no Sb/Br) - please check <http://www.ti.com/productcontent> for the latest availability information and additional product content details.

**TBD:** The Pb-Free/Green conversion plan has not been defined.

**Pb-Free (RoHS):** TI's terms "Lead-Free" or "Pb-Free" mean semiconductor products that are compatible with the current RoHS requirements for all 6 substances, including the requirement that lead not exceed 0.1% by weight in homogeneous materials. Where designed to be soldered at high temperatures, TI Pb-Free products are suitable for use in specified lead-free processes.

**Pb-Free (RoHS Exempt):** This component has a RoHS exemption for either 1) lead-based flip-chip solder bumps used between the die and package, or 2) lead-based die adhesive used between the die and leadframe. The component is otherwise considered Pb-Free (RoHS compatible) as defined above.

**Green (RoHS & no Sb/Br):** TI defines "Green" to mean Pb-Free (RoHS compatible), and free of Bromine (Br) and Antimony (Sb) based flame retardants (Br or Sb do not exceed 0.1% by weight in homogeneous material)

(3) MSL, Peak Temp. -- The Moisture Sensitivity Level rating according to the JEDEC industry standard classifications, and peak solder temperature.

(4) There may be additional marking, which relates to the logo, the lot trace code information, or the environmental category on the device.

(5) Multiple Device Markings will be inside parentheses. Only one Device Marking contained in parentheses and separated by a "~" will appear on a device. If a line is indented then it is a continuation of the previous line and the two combined represent the entire Device Marking for that device.

**Important Information and Disclaimer:** The information provided on this page represents TI's knowledge and belief as of the date that it is provided. TI bases its knowledge and belief on information provided by third parties, and makes no representation or warranty as to the accuracy of such information. Efforts are underway to better integrate information from third parties. TI has taken and continues to take reasonable steps to provide representative and accurate information but may not have conducted destructive testing or chemical analysis on incoming materials and chemicals. TI and TI suppliers consider certain information to be proprietary, and thus CAS numbers and other limited information may not be available for release.

In no event shall TI's liability arising out of such information exceed the total purchase price of the TI part(s) at issue in this document sold by TI to Customer on an annual basis.

**OTHER QUALIFIED VERSIONS OF TPS3813I50-Q1, TPS3813K33-Q1 :**

- Catalog: [TPS3813I50](#), [TPS3813K33](#)
- Enhanced Product: [TPS3813K33-EP](#)

## NOTE: Qualified Version Definitions:

- Catalog - TI's standard catalog product
- Enhanced Product - Supports Defense, Aerospace and Medical Applications

## TAPE AND REEL INFORMATION



### QUADRANT ASSIGNMENTS FOR PIN 1 ORIENTATION IN TAPE



\*All dimensions are nominal

Device	Package Type	Package Drawing	Pins	SPQ	Reel Diameter (mm)	Reel Width W1 (mm)	A0 (mm)	B0 (mm)	K0 (mm)	P1 (mm)	W (mm)	Pin1 Quadrant
TPS3813I50QDBVRQ1	SOT-23	DBV	6	3000	180.0	9.0	3.15	3.2	1.4	4.0	8.0	Q3
TPS3813K33QDBVRQ1	SOT-23	DBV	6	3000	180.0	9.0	3.15	3.2	1.4	4.0	8.0	Q3

**TAPE AND REEL BOX DIMENSIONS**



\*All dimensions are nominal

Device	Package Type	Package Drawing	Pins	SPQ	Length (mm)	Width (mm)	Height (mm)
TPS3813I50QDBVRQ1	SOT-23	DBV	6	3000	182.0	182.0	20.0
TPS3813K33QDBVRQ1	SOT-23	DBV	6	3000	182.0	182.0	20.0

# MECHANICAL DATA

DBV (R-PDSO-G6)

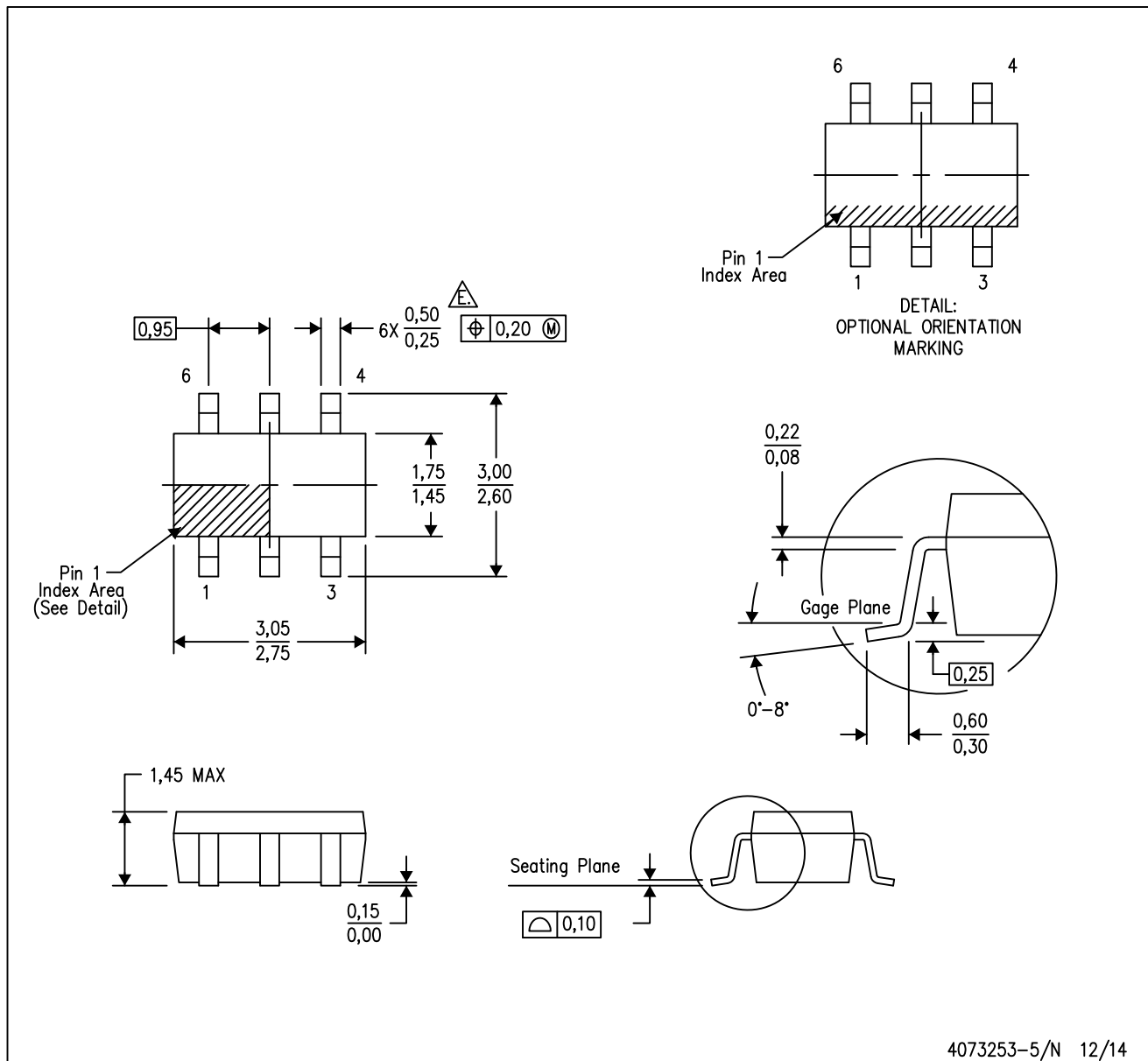
PLASTIC SMALL-OUTLINE PACKAGE



- NOTES:
- A. All linear dimensions are in millimeters.
  - B. This drawing is subject to change without notice.
  - C. Body dimensions do not include mold flash or protrusion. Mold flash and protrusion shall not exceed 0.15 per side.
  - D. Leads 1,2,3 may be wider than leads 4,5,6 for package orientation.
- Falls within JEDEC MO-178 Variation AB, except minimum lead width.

DBV (R-PDSO-G6)

PLASTIC SMALL OUTLINE

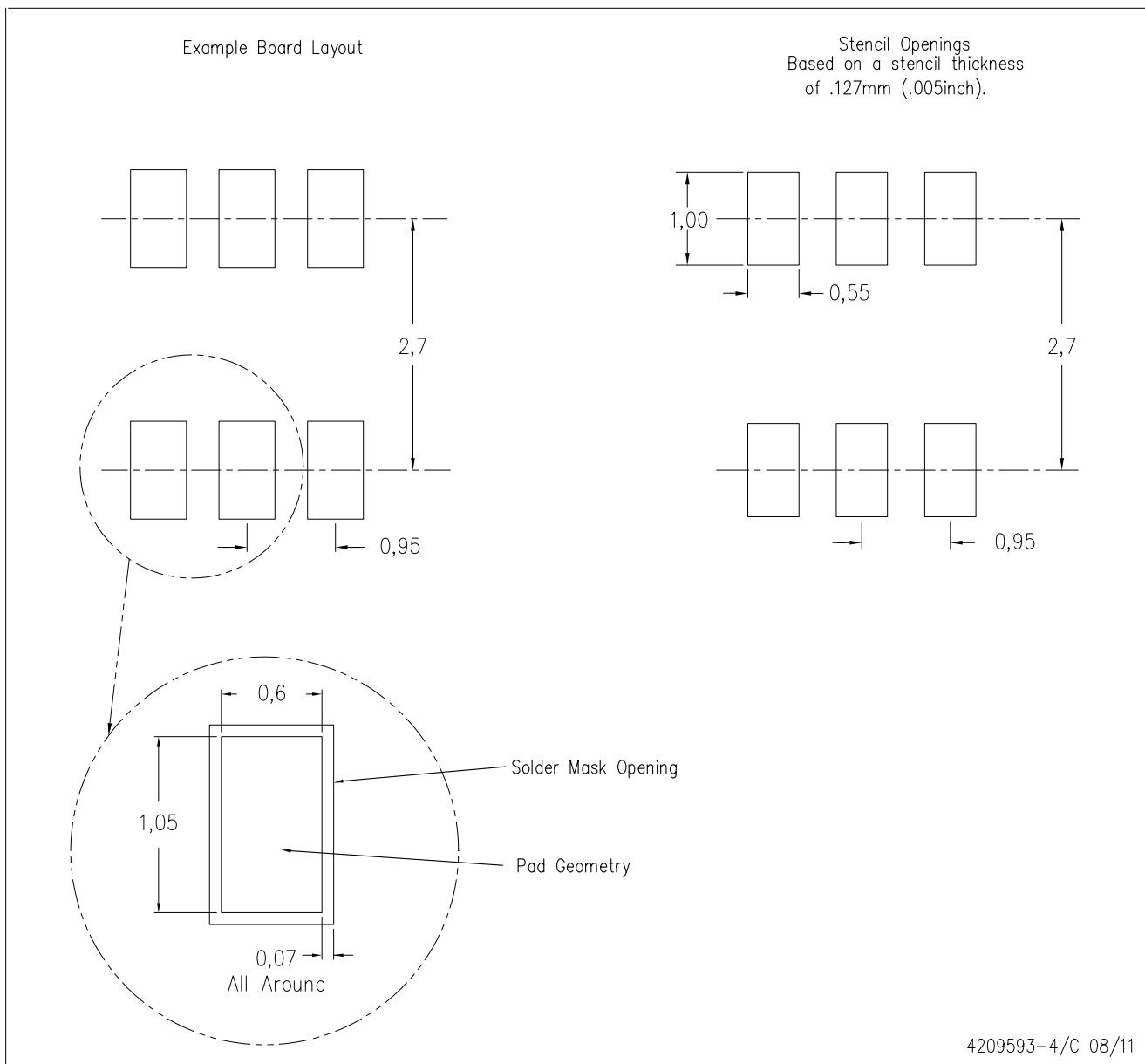

- NOTES:
- A. All linear dimensions are in millimeters.
  - B. This drawing is subject to change without notice.
  - C. Customers should place a note on the circuit board fabrication drawing not to alter the center solder mask defined pad.
  - D. Publication IPC-7351 is recommended for alternate designs.
  - E. Laser cutting apertures with trapezoidal walls and also rounding corners will offer better paste release. Customers should contact their board assembly site for stencil design recommendations. Example stencil design based on a 50% volumetric metal load solder paste. Refer to IPC-7525 for other stencil recommendations.

## IMPORTANT NOTICE

Texas Instruments Incorporated and its subsidiaries (TI) reserve the right to make corrections, enhancements, improvements and other changes to its semiconductor products and services per JESD46, latest issue, and to discontinue any product or service per JESD48, latest issue. Buyers should obtain the latest relevant information before placing orders and should verify that such information is current and complete. All semiconductor products (also referred to herein as "components") are sold subject to TI's terms and conditions of sale supplied at the time of order acknowledgment.

TI warrants performance of its components to the specifications applicable at the time of sale, in accordance with the warranty in TI's terms and conditions of sale of semiconductor products. Testing and other quality control techniques are used to the extent TI deems necessary to support this warranty. Except where mandated by applicable law, testing of all parameters of each component is not necessarily performed.

TI assumes no liability for applications assistance or the design of Buyers' products. Buyers are responsible for their products and applications using TI components. To minimize the risks associated with Buyers' products and applications, Buyers should provide adequate design and operating safeguards.

TI does not warrant or represent that any license, either express or implied, is granted under any patent right, copyright, mask work right, or other intellectual property right relating to any combination, machine, or process in which TI components or services are used. Information published by TI regarding third-party products or services does not constitute a license to use such products or services or a warranty or endorsement thereof. Use of such information may require a license from a third party under the patents or other intellectual property of the third party, or a license from TI under the patents or other intellectual property of TI.

Reproduction of significant portions of TI information in TI data books or data sheets is permissible only if reproduction is without alteration and is accompanied by all associated warranties, conditions, limitations, and notices. TI is not responsible or liable for such altered documentation. Information of third parties may be subject to additional restrictions.

Resale of TI components or services with statements different from or beyond the parameters stated by TI for that component or service voids all express and any implied warranties for the associated TI component or service and is an unfair and deceptive business practice. TI is not responsible or liable for any such statements.

Buyer acknowledges and agrees that it is solely responsible for compliance with all legal, regulatory and safety-related requirements concerning its products, and any use of TI components in its applications, notwithstanding any applications-related information or support that may be provided by TI. Buyer represents and agrees that it has all the necessary expertise to create and implement safeguards which anticipate dangerous consequences of failures, monitor failures and their consequences, lessen the likelihood of failures that might cause harm and take appropriate remedial actions. Buyer will fully indemnify TI and its representatives against any damages arising out of the use of any TI components in safety-critical applications.

In some cases, TI components may be promoted specifically to facilitate safety-related applications. With such components, TI's goal is to help enable customers to design and create their own end-product solutions that meet applicable functional safety standards and requirements. Nonetheless, such components are subject to these terms.

No TI components are authorized for use in FDA Class III (or similar life-critical medical equipment) unless authorized officers of the parties have executed a special agreement specifically governing such use.

Only those TI components which TI has specifically designated as military grade or "enhanced plastic" are designed and intended for use in military/aerospace applications or environments. Buyer acknowledges and agrees that any military or aerospace use of TI components which have **not** been so designated is solely at the Buyer's risk, and that Buyer is solely responsible for compliance with all legal and regulatory requirements in connection with such use.

TI has specifically designated certain components as meeting ISO/TS16949 requirements, mainly for automotive use. In any case of use of non-designated products, TI will not be responsible for any failure to meet ISO/TS16949.

### Products

Audio	<a href="http://www.ti.com/audio">www.ti.com/audio</a>
Amplifiers	<a href="http://amplifier.ti.com">amplifier.ti.com</a>
Data Converters	<a href="http://dataconverter.ti.com">dataconverter.ti.com</a>
DLP® Products	<a href="http://www.dlp.com">www.dlp.com</a>
DSP	<a href="http://dsp.ti.com">dsp.ti.com</a>
Clocks and Timers	<a href="http://www.ti.com/clocks">www.ti.com/clocks</a>
Interface	<a href="http://interface.ti.com">interface.ti.com</a>
Logic	<a href="http://logic.ti.com">logic.ti.com</a>
Power Mgmt	<a href="http://power.ti.com">power.ti.com</a>
Microcontrollers	<a href="http://microcontroller.ti.com">microcontroller.ti.com</a>
RFID	<a href="http://www.ti-rfid.com">www.ti-rfid.com</a>
OMAP Applications Processors	<a href="http://www.ti.com/omap">www.ti.com/omap</a>
Wireless Connectivity	<a href="http://www.ti.com/wirelessconnectivity">www.ti.com/wirelessconnectivity</a>

### Applications

Automotive and Transportation	<a href="http://www.ti.com/automotive">www.ti.com/automotive</a>
Communications and Telecom	<a href="http://www.ti.com/communications">www.ti.com/communications</a>
Computers and Peripherals	<a href="http://www.ti.com/computers">www.ti.com/computers</a>
Consumer Electronics	<a href="http://www.ti.com/consumer-apps">www.ti.com/consumer-apps</a>
Energy and Lighting	<a href="http://www.ti.com/energy">www.ti.com/energy</a>
Industrial	<a href="http://www.ti.com/industrial">www.ti.com/industrial</a>
Medical	<a href="http://www.ti.com/medical">www.ti.com/medical</a>
Security	<a href="http://www.ti.com/security">www.ti.com/security</a>
Space, Avionics and Defense	<a href="http://www.ti.com/space-avionics-defense">www.ti.com/space-avionics-defense</a>
Video and Imaging	<a href="http://www.ti.com/video">www.ti.com/video</a>

### TI E2E Community

[e2e.ti.com](http://e2e.ti.com)